

Application

KWT valves are very varied and are used in connection to surface, sewer and process water systems. They are a very simple yet effective way to reliably prevent backflow into the system.

Operation

The correct flapvalve can be easily calculated by using an advanced calculation program. Dynamic preconditions play a decisive role, in particular in relation to certain applications as well as static conditions. KWT advises and supplies the correct flapvalve for all applications, regardless of whether they are being used in tidal, pumped or gravitational outflow applications. All our products are carefully calculated regarding strength and are produced using only pure, high-quality materials.

A flapvalve consists mainly of a plate that is hinged on the top side, connected to a mounting frame. It therefore forms an on-seated seal on the front of the culvert/pipe. Water discharging from the pipe opens the flap, however when the head increases on the downstream side, the flap is pressed against its seal, preventing backflow. KWT flapvalves require only a small head in the pipe to open the flap, as HDPE floats in water- the flapvalves are fitted with a counterweight to balance the flap correctly.

The flapvalve is light in weight, making the flapvalves easy to install, very responsive and also very reliable. The valves are available in various forms, such as the vertically hung flat wall mounted type, as well as pipe mounted, flange mounted and angled wall mounted (mounted on a 15° backward angle to reduce the effect of waves and ensure a good seal).

KWT produces discharge and pump valves as standard in sizes from 100mm diameter upwards, and are happy to assist where something special is required. Please contact our sales department for more information or advice.

Benefits

Easy to install.

Relatively light in weight because HDPE is used.

Virtually maintenance free.

**KWT**®
Waterbeheersing

Tel: +31 (0)321 33 55 66

Fax: +31 (0)321 33 55 76

E-mail: kwtwaterbeheersing@kwtgroup.nl

www.kwtgroup.nl



Type: KLK-R-O

Customised production.

Short turnaround.

Specifications

Sizes: Ø 100 mm to Ø 500 mm

Operating pressure: Maximum 5 MwC

Valve cover angle: 15° as standard except for flat-mounted wall models

Higher pressures and larger dimensions on request.

Various connection options such as: PVC/HDPE tube, flange, wall, under an angle, concrete/SPIROsol.

Materials

Valve plate: HDPE

Back plate: HDPE

Shaft and ballast weight: SS316

Seal: EPDM seal

Other materials on request.

KWT® Flapvalve type: KLK 100-500

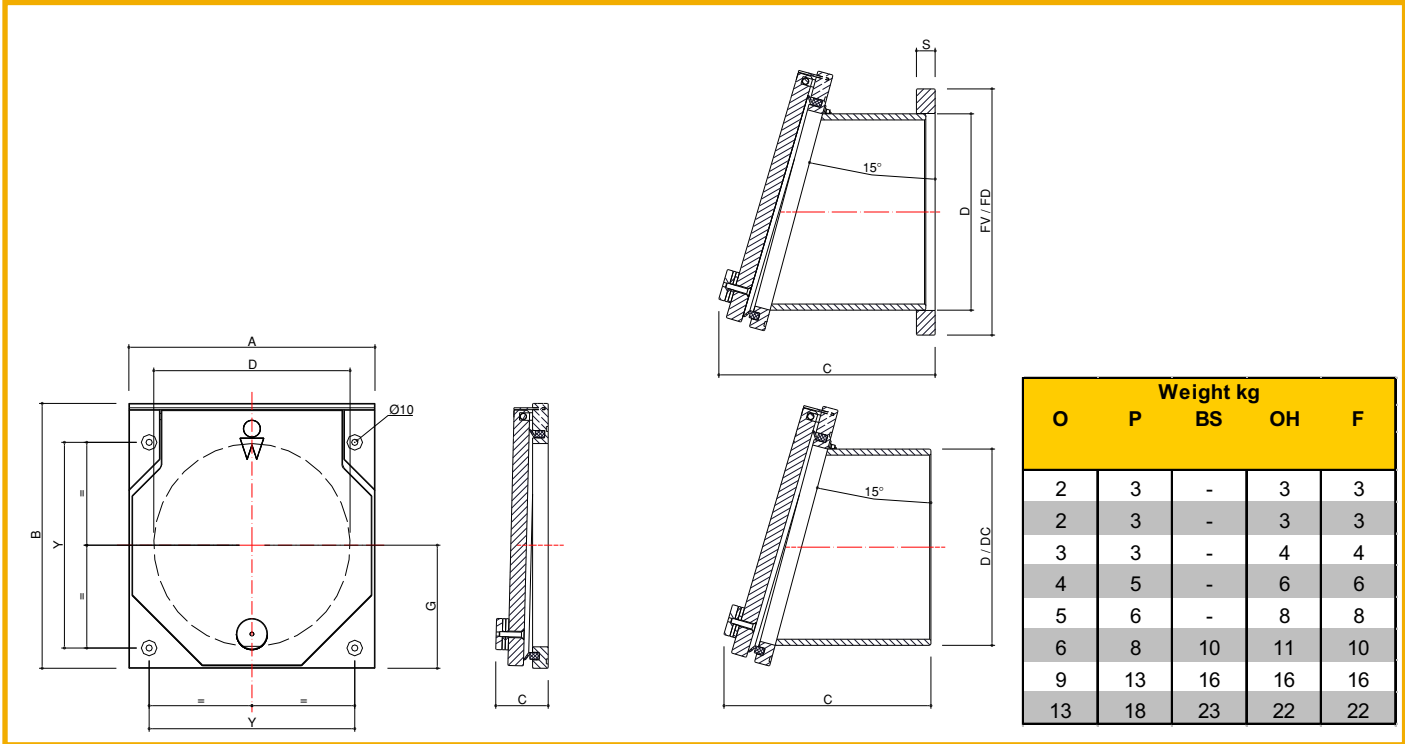

KLK-R-O

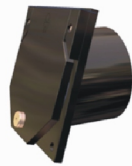

KLK-R-P

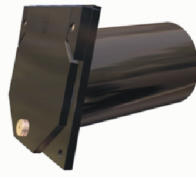

KLK-R-BS

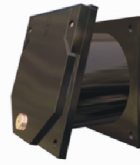

KLK-R-OH

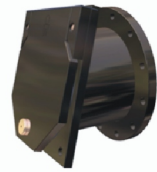

KLK-R-F

NW mm	D mm	A mm	B mm	type O		type P		type BS			type OH / F				G mm	Y mm	
				C mm	C mm	C mm	C mm	C mm	C mm	DC mm	C mm	C mm	FV mm	FD mm			S mm
					open		open		open			open		Ø			
100	110	190	220	75	230	225	345	-	-	-	235	355	190	220	20	95	150
125	125	205	235	75	245	225	355	-	-	-	235	365	205	220	20	102,5	155
150	160	240	270	75	280	225	380	-	-	-	235	390	240	285	20	120	180
200	200	280	310	75	315	325	510	-	-	-	340	525	280	340	30	140	230
250	250	330	360	80	360	330	545	-	-	-	345	560	330	395	30	165	280
300	315	395	425	85	425	335	595	585	845	290	350	610	395	445	30	197,5	330
400	400	480	510	95	510	400	710	595	910	390	410	725	480	565	30	240	420
500	500	580	610	105	600	400	785	605	985	490	420	800	580	670	30	290	520

Description for tenders.

Flap valve, KLK 100-500 type

Manufactured by: KWT Waterbeheersing

Materials: HDPE, SS316, EPDM

Standard passage: Ø 100 mm to Ø 500 mm

Working pressure: Maximum 5 MwC

Produced as one piece where the type of valve is indicated in connection with the connection. The valve plate and the back plate are produced using HDPE. The hinge pin and ballast weight are produced in SS316 as standard. The ballast weight can be easily adjusted if required. The sealing consists of an EPDM lip seal in the back plate. The valve plate is also installed under an angle in relation to the back plate in connection to flat-mounting. This boosts correct sealing.

